



Installation and Operating Manual
Smart Comfort 5/SC-FT
 - Please forward to the user -

Contents:	Page:
About this manual, Safety instructions, Disposal	2
Technical data, Shipping unit	3
Installation	5
Electrical connection	7
Programming of the device type	12
Operating element - setting options	13
Factory settings, Frost protection	17
Filter replacement and filter cleaning	18

1 2

About this manual

EN

- Read this manual carefully and completely before assembly! Always observe the general safety instructions and the safety symbols with information in the text.
- Hand out this manual to the user (tenants, proprietors, property management etc.) after completing assembly.
- **Symbols in this manual:**



This symbol warns you against risks of injury



This symbol warns you against risks of injury from electricity

Safety instructions



Caution! Any assembly work may only be carried out after disconnecting the supply voltage!



Attention! The electric connection may only be made by authorised qualified personnel and according to the applicable version of VDE 0100!

Disposal



The packaging must be sorted before disposal. If you wish to dispose of the ventilation device, observe the currently applicable regulations. Pursuant to the German Electrical and Electronic Equipment Act (ElektroG) this device can be returned to your municipal collection point free of charge.

Technical data

EN

Control		Power supply units	
Operating voltage:	12 V DC	Input voltage:	100 - 240 V AC
Functional voltage range:	0 - 10 V	Output voltage:	12 V DC
Operational switching current:	max. 5 A	Types:	
Connected load:	max. 60 W	5/NT18	18 Watt Order No.: 039 973
		5/NT60	60 Watt Order No.: 039 974
		5/NT100	100 Watt Order No.: 040 096

Shipping unit

The control and the operating unit with frame are supplied as one shipping unit. The power supply is a separate shipping unit. A switch box is to be provided by the customer.

Please check the delivery for completeness and mint condition!

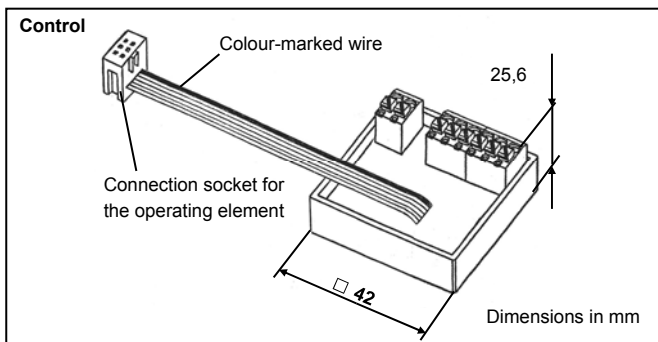

3

Operating element with frame

EN

Operating element with frame

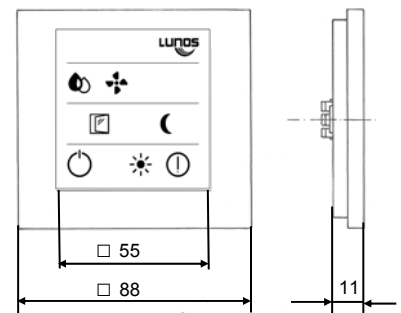

Power supply
Example 5/NT18

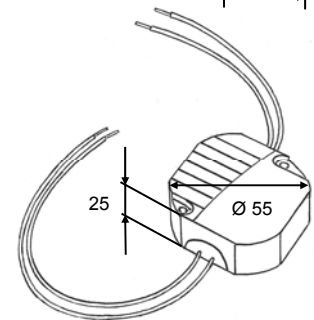

Dimensions in mm

4

Installation

EN

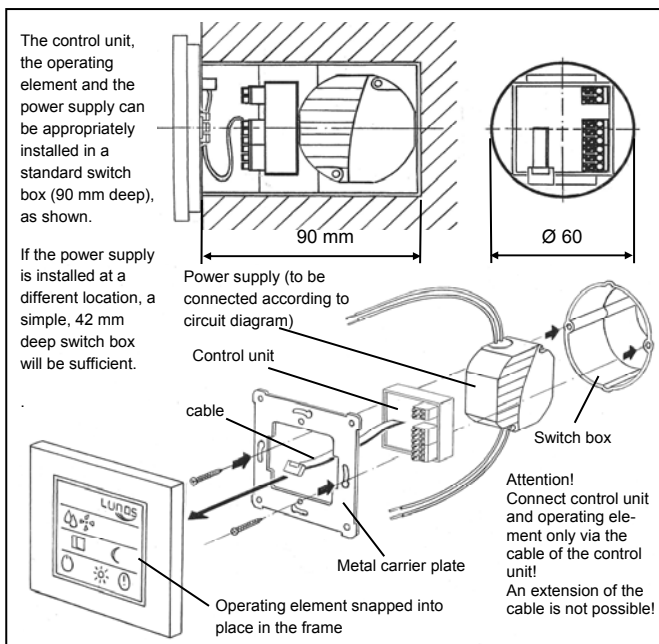

5

EN

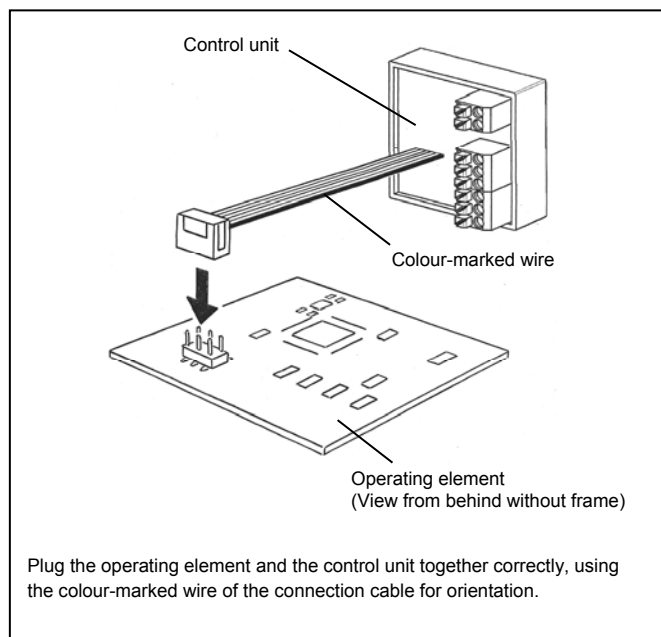

6

Electrical connection

EN

Safety instructions

- ⚠ Caution! Any assembly work may only be carried out after disconnecting the supply voltage!
- ⚠ Before connecting the device to the mains voltage, make sure that all connection lines are voltage-free (dead)! (Separation from the power supply with a minimum contact opening of 3 mm, e.g. electric fuse).
- ⚠ Each electric circuit of this ventilation system must be fitted with a residual current protection (e.g. FI switch/RCCB)!
- ⚠ Electrical connection only by a specialist.

Additional installations and electrical components in the ventilation unit are not admissible!

Use the following cables for electrical connection:

- Cable to the ventilation devices: e.g. J-Y (St) Y 2 x 2 x 0.8, max. 1.5 mm²
- Cable for the supply voltage: e.g. NYM 3 x 1.5 mm²

7

EN

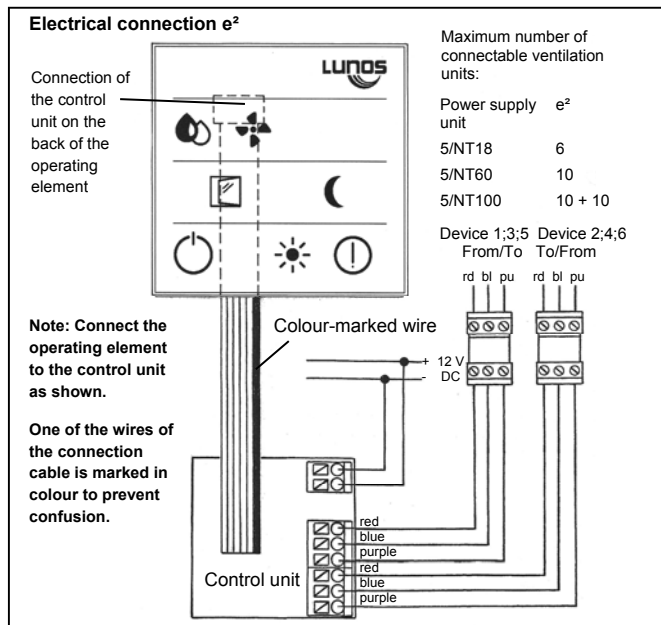

8

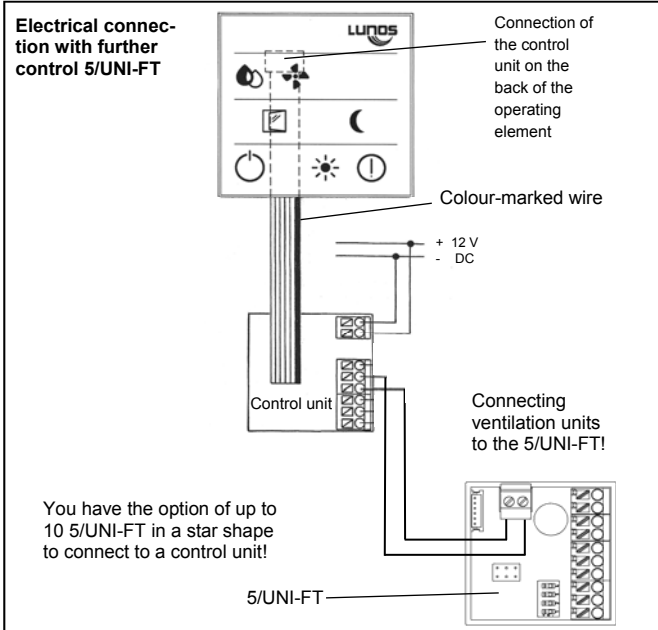
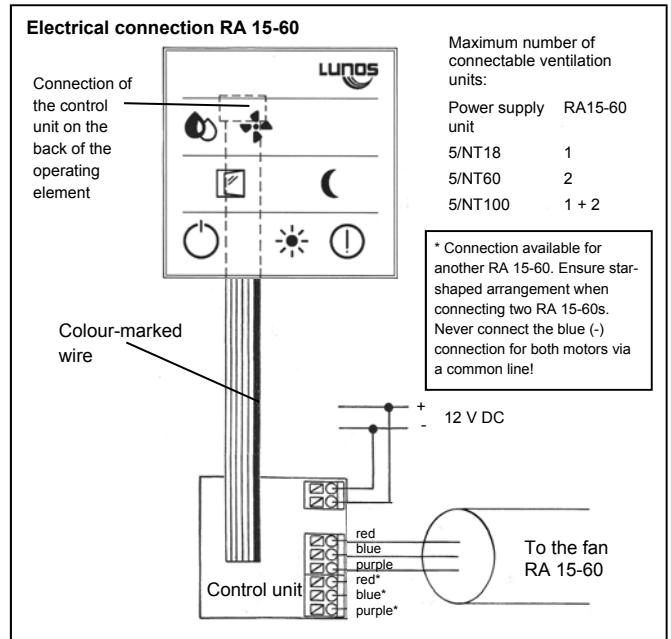
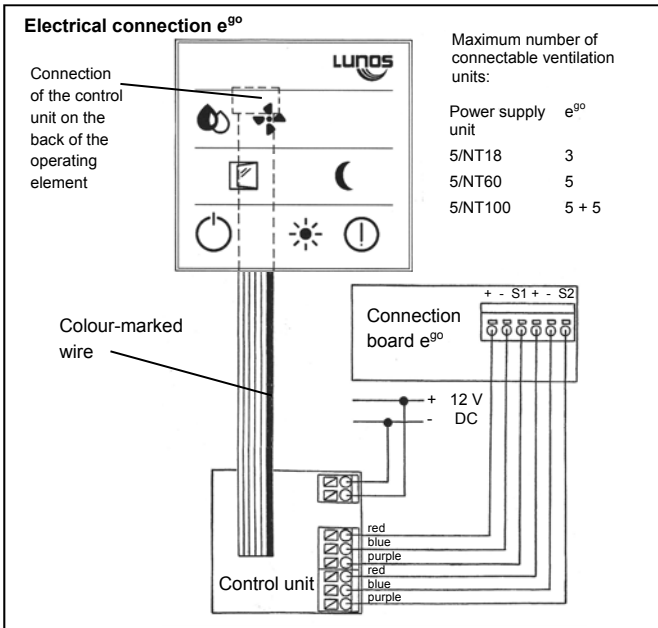







If the "Event" button is pressed for 10 seconds or longer, you enter the device mode. This is confirmed by a permanent flashing of the Event LED. The connected fan type can now be selected via the "Fan" button. The fan type is accepted after 10 seconds without input. The Event LED lights up for a long time and then goes out.

	Type	Display	1 st Stage	2 nd Stage	3 rd Stage	4 th Stage
1	e ²	●○○○	15 m ³ /h	20 m ³ /h	30 m ³ /h	38 m ³ /h
2	e ² neo	○●○○	5 m ³ /h	15 m ³ /h	30 m ³ /h	38 m ³ /h
3	e ² short	○○●○	15 m ³ /h	20 m ³ /h	30 m ³ /h	38 m ³ /h
4	e ² mini	○○○●	5 m ³ /h	10 m ³ /h	15 m ³ /h	20 m ³ /h
5	e ⁹⁰	●●○○	5 m ³ /h	10 m ³ /h	15 m ³ /h	20 m ³ /h
6	e ⁹⁰	●●●○	5 m ³ /h	10 m ³ /h	20 m ³ /h	45 m ³ /h*
7	RA 15-60	●●●●	15 m ³ /h*	30 m ³ /h*	45 m ³ /h*	60 m ³ /h*
8	5/UNI-FT**	○●●●	Stages according to the setting on the 5/UNI-FT			

* only exhaust air

** Activation of the summer mode has no effect when using a 5 / UNI-FT, as it must be activated locally at the universal control. Please refer to the installation manual for the 5 / UNI-FT.

Symbol	Single button press	Button pressed for 3 seconds	Button pressed for 10 seconds
	Activating or deactivating the humidity-sensitive automatic mode	Setting of the lowest ventilation stage in the automatic mode	Adjustment of the lower control limit in the automatic mode
	Setting of the airflow volume	Changeover between 5-stage and 8-stage operation	-
	Activating or deactivating the intensive ventilation	Changing the runtime of the intensive ventilation	Setting of the stage for the intensive ventilation
	Activating or deactivating the night-time reduction	Defining the runtime of the night-time reduction	Defining the active stage during night-time reduction
	Activating or deactivating the summer mode	Defining the operating time of the summer mode	-
	Switching on the ventilation system Setting of the LED brightness level	Switching off the ventilation system	-
	-	Resetting the filter replacement	Programming of the device type

An advanced feature description can be found on www.lunos.de

The Smart Comfort offers you the possibility to switch all functions of your ventilation devices and to recognize their current operating status. It contains a humidity sensor, which controls the ventilation devices appropriately in automatic operation.

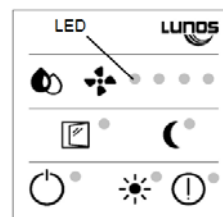

Drop

The humidity-sensitive automatic mode is activated or deactivated via the button with the drop symbol. In automatic mode, the LEDs 1-4 light up in low brightness. The active stage is displayed with full brightness. In the standard, the first stage is switched at a relative humidity of 50%. The highest ventilation stage is switched from a humidity value of 70%.



Fan

The ventilation stage can be set using the "Fan" button. The manual adjustment of the ventilation stage is performed in a rolling manner, i.e. each pressure on the button increases the stage by one. After the highest stage, the lowest stage or OFF follows again. When the automatic mode is activated, manual changes of the ventilation stage are valid for one hour.



Window

The window symbol stands for the intensive ventilation mode. When activated, the LED next to the symbol illuminates continuously and the fans change to the highest available ventilation stage. The mode automatically ends after the set time (factory setting: 30 minutes). The ventilation system then switches back to the previously set operating mode (manual or automatic mode).



Moon

Pressing the "Moon" button activates or deactivates the night reduction. In the factory setting, the ventilation system goes to the "OFF" stage and the LEDs light up with low brightness. The system automatically returns to the previously set mode after the set time has elapsed (factory setting: 8 hours). The LEDs light up again with full brightness.



Sun

This button is used to activate and deactivate the summer mode. When the mode is active, the LED next to the symbol illuminates. By the activation, only the reversing time, i.e. the change between supply air and exhaust air operation of each unit, is increased to one hour. The mode runs according to the set runtime (factory setting: 8 hours). By the increase, heat recovery is bypassed and cool air can be supplied to the utilisation unit and distributed by means of effective cross ventilation.



ON/OFF

The brightness of the LEDs can be adjusted in a rolling manner by a simple push of this button. It is switched between OFF, dark and bright. If the button is pressed for three seconds, the ventilation system will be switched off completely. To turn a flick of the button.



Event

Press the "Event" button for 3 seconds to confirm that a filter replacement has been carried out. A successful reset is confirmed by a triple flashing of the Event LED.

You can use the buttons described above to carry out further programming. It is also possible to set the operating times and ventilation stages of the comfort functions as well as to calibrate the airflow volumes of your ventilation units.

For further information, please contact LUNOS Lüftungstechnik GmbH für Raumluftsysteme.

Factory settings EN

The factory settings are as follows:

- Device type: e²
- Automatic mode: the lowest stage in humidity-sensitive mode is the lowest ventilation stage, i.e. without OFF. Control range 50% -70%
- Intensive ventilation: active for 30 minutes, highest ventilation stage
- Night reduction: active for 8 hours, ventilation stage OFF
- Summer ventilation: active for 8 hours, reversing time 1 hour

By pressing and holding the “Sun” and “Event” buttons for 10 seconds, the factory settings are restored. The control starts again and all LEDs light up briefly three times.

Frost protection

If the room temperature drops below 8°C for more than one hour, the fan is switched off automatically. If a temperature of 15°C is exceeded, the fan is switched on again.
The Event LED lights up three times every 15 seconds.

Notes EN

Filter replacement and filter cleaning EN

The Event LED of the operating element illuminates continuously to signalise that a filter is dirty.
Remove the inner screen of the ventilation unit, remove the filter, insert the new or cleaned filter, put the inner screen back on.
Reset the filter monitoring display by pressing the “Event” button for three seconds. The function is reset.
LED illuminates continuously when filter is dirty

Example inner screen e²

Please note the filter replacements you have carried out. (Filters should be changed approx. 3 months after the last filter replacement):

Filter replacement date	Expected filter replacement	Type of filter used

17 18

Notes EN



19 20