

5/UNI-FT & RF - Montage Feuchtesensor/LED an Schalter 5/W2U

Schritt 1: Klemmen korrekt belegen

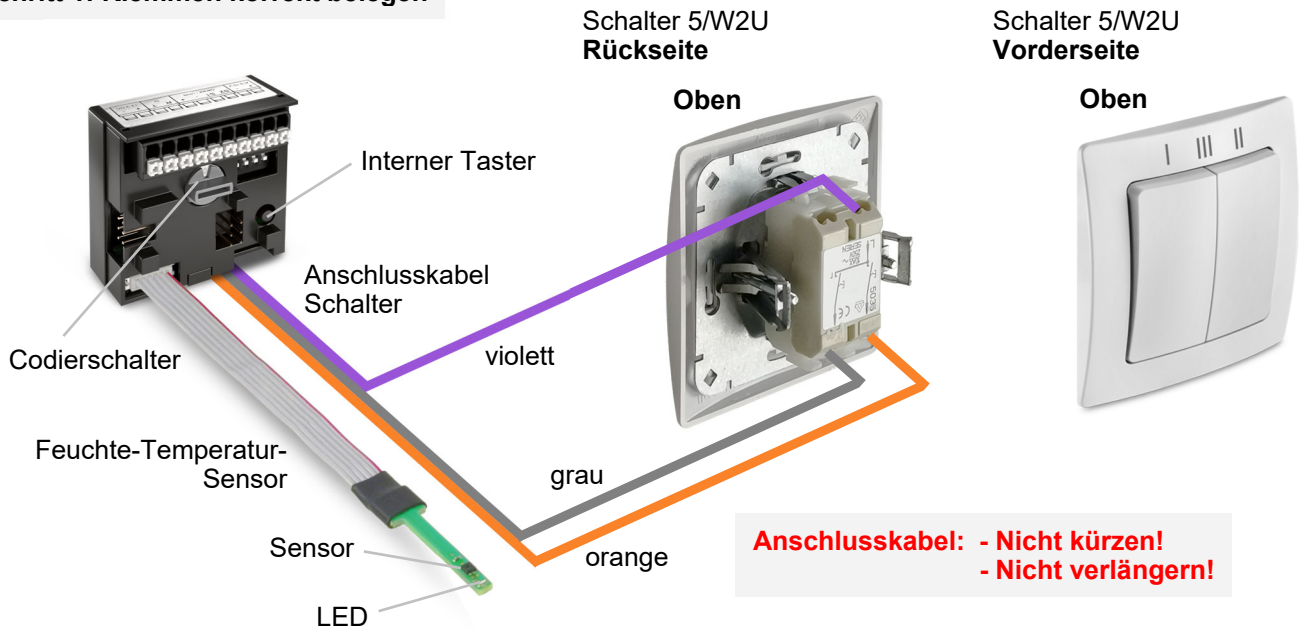

Schritt 2: Rückseitigen Aufkleber durchstechen

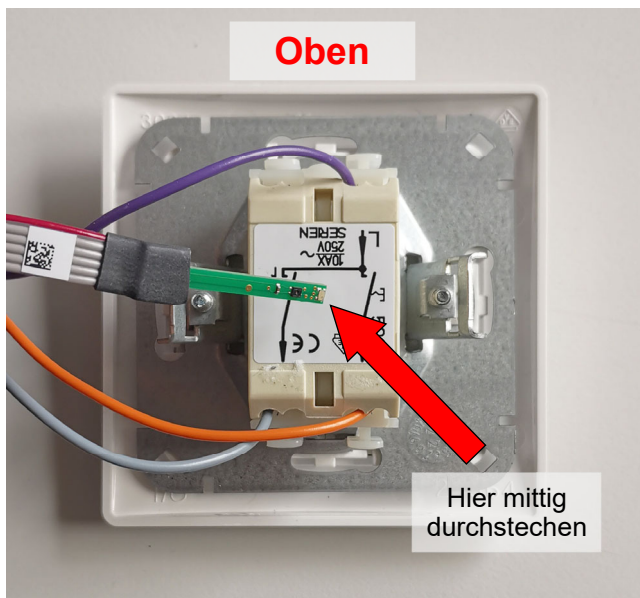

Schritt 3: Feuchtesensor/LED einstecken

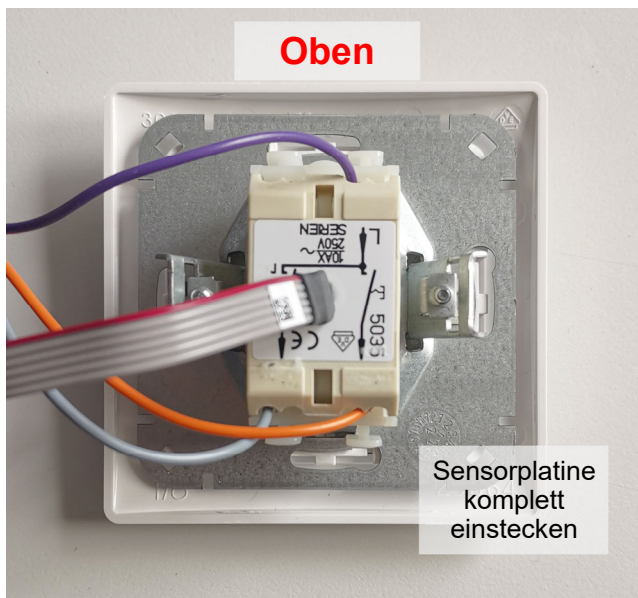

Schritt 4: Steuerung und Schalter in UP-Dose einbauen - fertig

Hinweis: 5/W2U = Fabrikat Kopp, Serie Paris (arktis weiß)

Der Montagehinweis dient zur Information – die Nutzung der Einbauanleitung ist weiterhin verpflichtend!

5/UNI-FT & RF - Mounting humidity sensor/LED on switch 5/W2U

Step 1: Assign terminals correctly

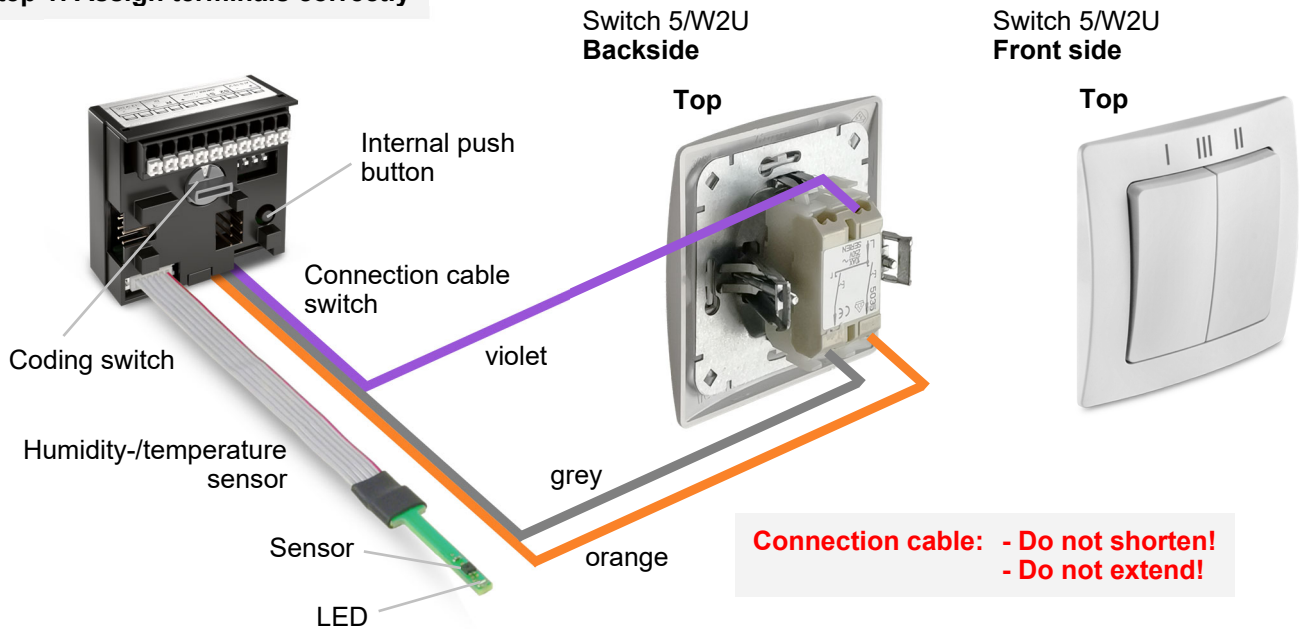

Step 2: Pierce the sticker on the back

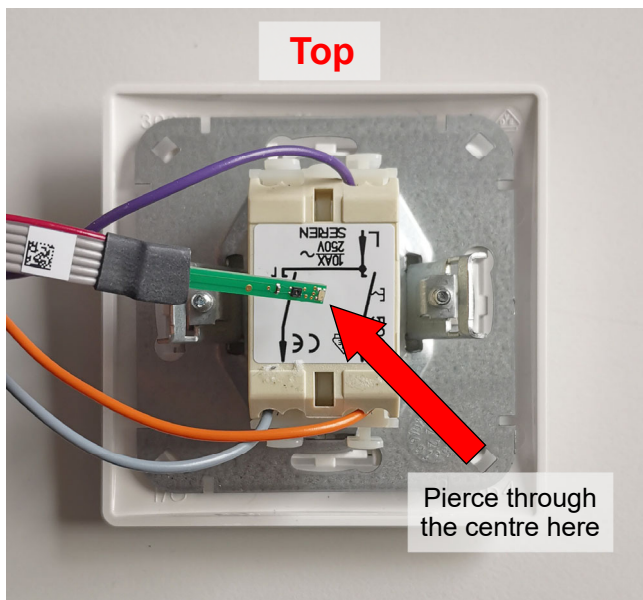

Step 3: Insert humidity sensor/LED

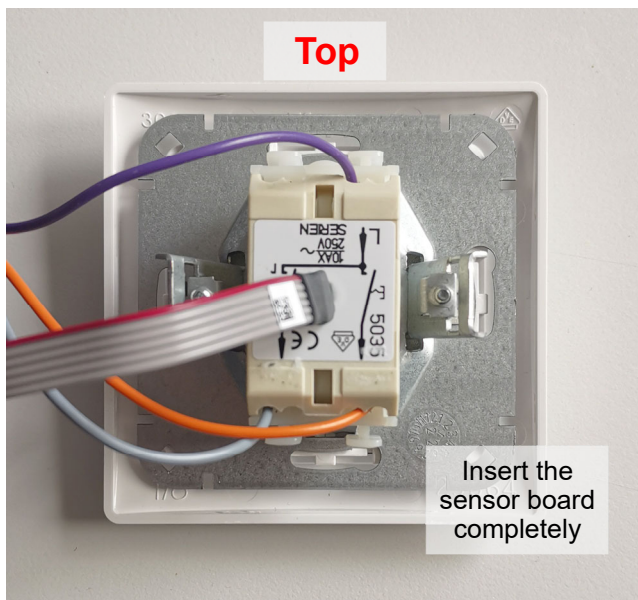

Step 4: Install control unit and switch in flush-mounted box - done

Note: 5/W2U = Brand Kopp, series Paris (arctic white)

The mounting advice is for information only – the use of the installation manual is still obligatory!